

REVISIONS			
REV	DESCRIPTION	DATE	APPROVED
--	--	--	--

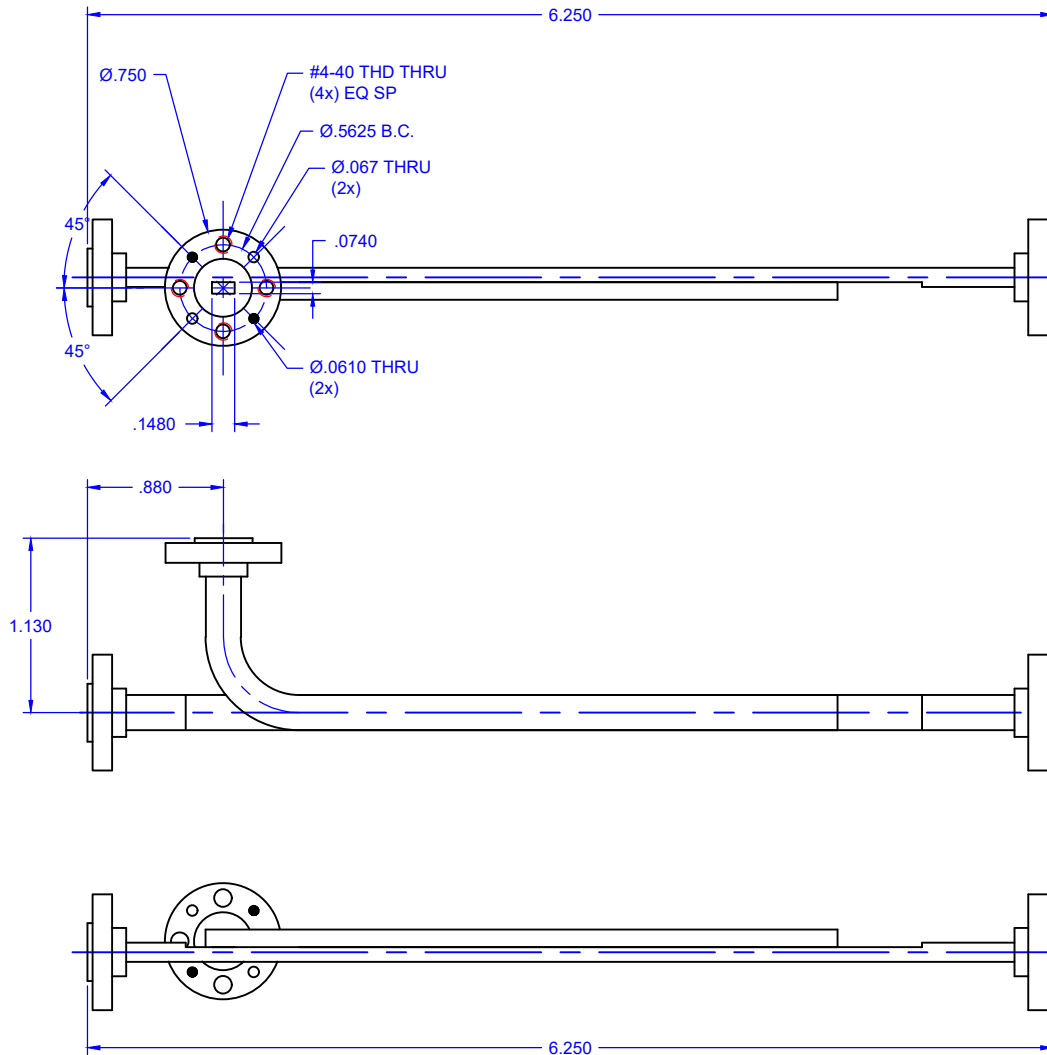

1	21664	V BAND LOAD	--
1	21404	CROSS ARM	2
1	21403	THRU ARM	1
QTY	PART NUMBER	DESCRIPTION	ITEM

UNLESS OTHERWISE SPECIFIED
ALL SURFACES $\sqrt{32}$

DIMENSIONS ARE IN INCHES
TOLERANCES ARE:
DECIMALS: .1234 +/- .0005
.123 +/- .005
.12 +/- .01
ANGLES: +/- .5 DEGREES

ALL THREADS TO BE 2A OR 2B
REF DWG# --

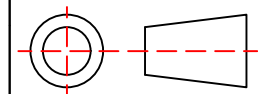

THIRD ANGLE PROJECTION

DRAFTING: MRN

APPROVED: M.S.

DATE: 10/13/2011

SHEET NO.
1

OF
1

Mi-Wave Millimeter Products Inc.

TITLE

559V/385
10,20,30,40 dB
ASSEMBLY

SIZE
A

DWG NO

21405